

Kawanishi N1K1 Kyofu

Card model

SCALE 1:48

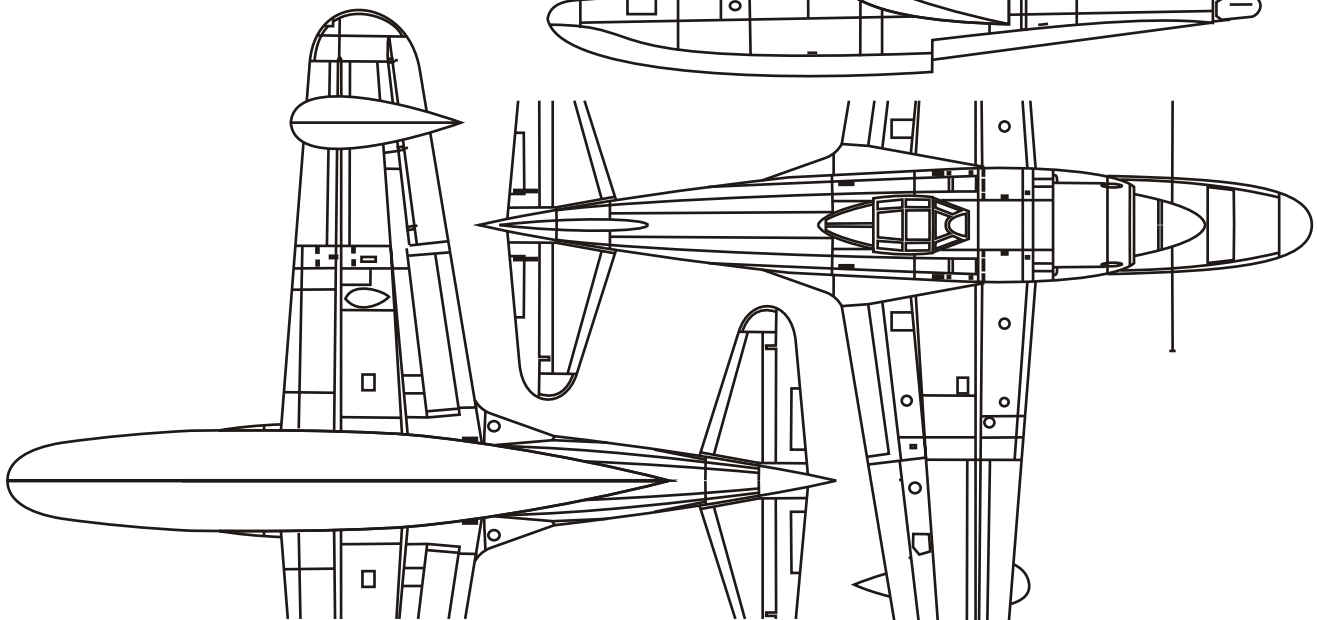
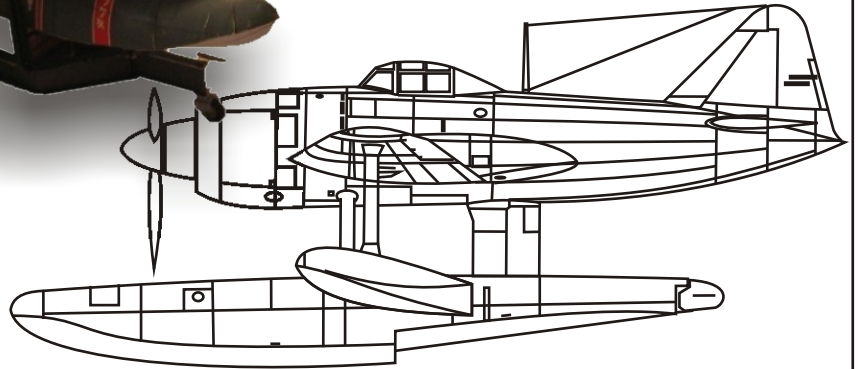

Wingspan	39 ft. 4 7/16 in.
Length	34 ft. 8 7/8 in.
Height	15 ft. 7 in.
Wing area	252.591 sq. ft.
Empty weight	6,067 lb.
Loaded weight	7,716 lb.
Maximum weight	8,184 lb.
Maximum speed	304 mph at 18,700 ft.
Cruising speed	230 mph at 6,560 ft.
Maximum range	1,036 st. miles

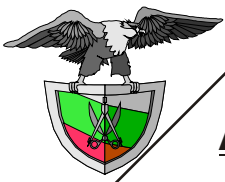

A little history:

The N1K Kyofu (Mighty Wind) appeared too late for its intended role of giving air support to amphibious forces where carriers were not available, or where airfields could not be built. Its combat career was brief and unspectacular, but its sound design led directly to its adaptation into the land-based N1K-J Shiden and Shiden-KAI, two of the finest land-based fighters of the entire Second World War. The Imperial Japanese Navy initiated development of single-seat floatplane fighters in 1940. Kawanishi Aircraft Co. Ltd. was instructed to begin designing a purpose-built floatplane fighter in September 1940.

The first Kyofu made its maiden flight on May 6, 1942; the flight was mostly successful, but continued teething troubles with the contra-rotating propeller's gear box led Kawanishi to substitute a regular three-bladed propeller mounted on an extension shaft for the second prototype. This necessitated the replacing of the prototype's Kasei 14 engine with the similarly-rated Kasei 13. The second prototype was much more reliable, but also had greater torque on take-off, meaning that the pilot had to be skillful and be ready to compensate for it. One in the air, though, the N1K handled pleasantly, and the use of "combat" flaps, similar to those on the Nakajima Ki-43 Hayabusa, gave the Kyofu remarkable maneuverability for a floatplane. Six service-test aircraft were built and delivered to the Navy, and Navy pilots liked the new plane despite its torque problems. Like the A6M2-N, the Kyofu was armed with two fuselage-mounted 7.7mm machine guns and two wing-mounted 20mm cannon. It promised to be much better than the A6M2-N.

The Kyofu began quantity production in July 1943 as the N1K1 Fighter Seaplane Kyofu Model 11, but production never reached more than 15 aircraft a month, and the changing situation meant that the Kyofu would never be used in its design role. Therefore, in December 1943, the Japanese Navy decided to cease the N1K1's production in March of the following year. Just 89 production Kyofus were built.

The Otsu Kokutai was the only unit to use the N1K1 (which was given the code name Rex) operationally. This unit served in the interception role against American B-24s over Balikpapan, Borneo, and later, after withdrawal to the home islands, flew from the surface of Lake Biwa in the air defense role. Although fated never to be used as a floatplane fighter supporting offensive operations, the Kyofu nevertheless was basically an excellent design, and was swiftly adapted into a land-based fighter.



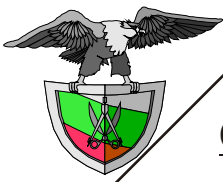

Overview of the model:

The present model can be built in several levels of difficulty. The beginners should choose the easy level, without hidden constructions. For the more advanced modelers I have given the opportunity to build the interior of the cockpit and the 14-cylinder engine. To model the interior, you need to build a hidden construction, which is easy to make. There is also a transporter for the plane included. You can build the model with or without hidden tabs.



Instructions on printing and assembling the model

The elements of the plane cover six pages. Depending of the level of difficulty you must print all pages or just a part of them. The elements are positioned in the following manner:

- **Pages 1,2 and 3:** main elements; these pages must all be printed out.
- **Page 4:** Here are the elements, needed for modeling the interior of the cockpit, the engine and the hidden construction. Here you'll also find a second version of the propeller blades.
- **Page 5:** Here are the elements needed to model the transporter.
- **Page 6:** Additional tabs

Print the necessary files on thin cardboard, Letter format. On pages 4&5 you'll find areas with red borders, cut them and glue them on a thick cardboard (0.02" thick for example). Then you can cut out the elements from these areas.

Each element has an identifier, which is a combination of a letter and a number. The groups are as follows:

- **A** - main elements, needed for all the difficulty levels
- **C** - elements for the hidden construction and the interior of the cockpit
- **E** - elements for the engine
- **T** - elements for the transporter

The additional tabs have no identifiers, but you'll find on them the IDs of the elements they are used to assemble. On the first three pages the tabs have either black or green borders. The black border means that this tab is in use, whether you use the additional tabs or not. The green border means that the tab is used only if you do not use additional tabs. If you use them, cut out the green-bordered tabs. At the end you'll find a table with the IDs, locations and the quantity of the elements.

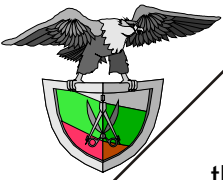

Below you'll find the assembly instructions. The stages of building the interior, the hidden construction and the engine can be overridden, if you have chosen the "easy" level of difficulty.

1. Build the hidden construction and glue to it the elements of the interior as shown of Fig.1.

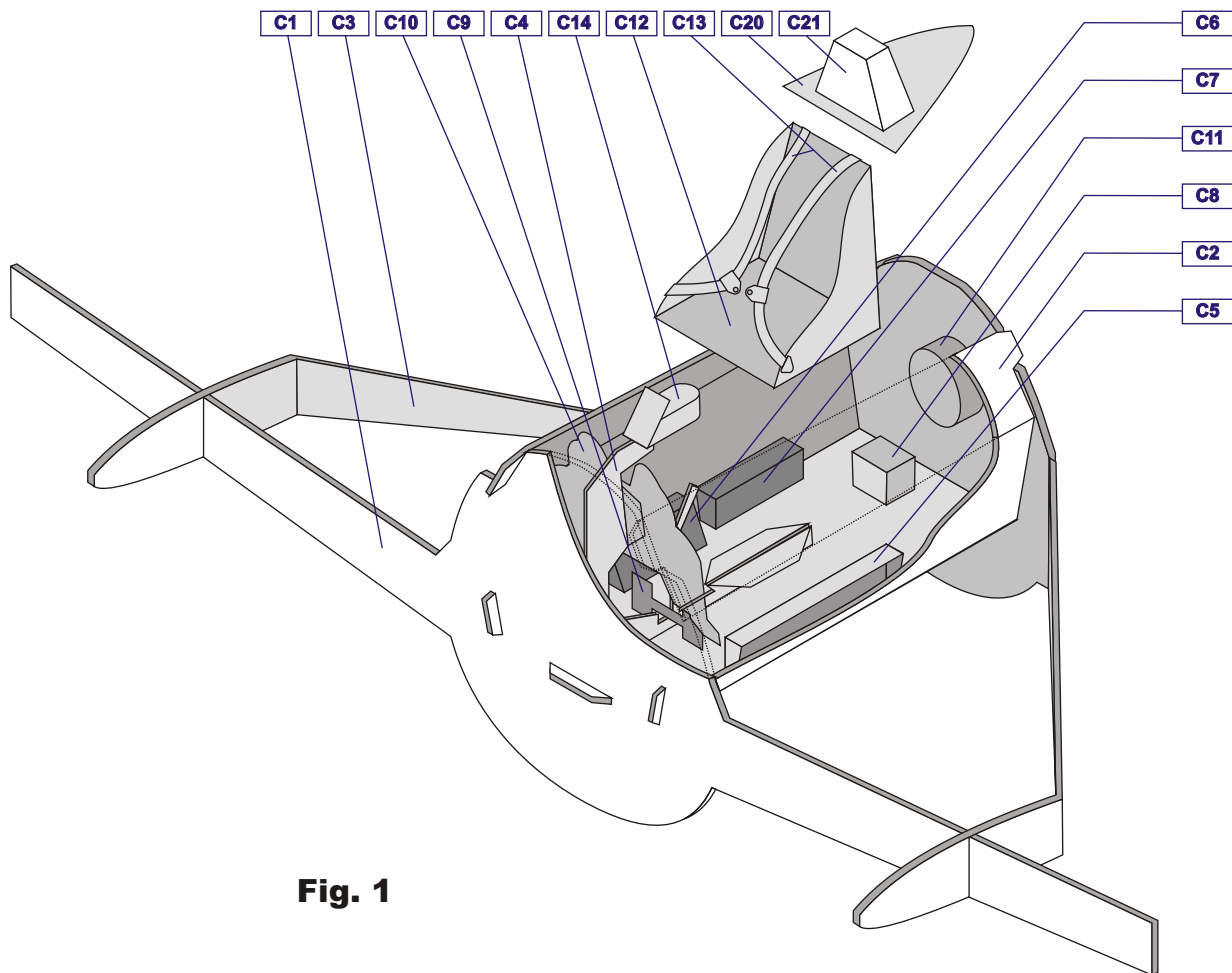
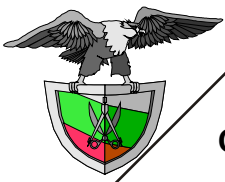

Fig. 1

2. Assemble the fuselage (elements A1 to A8).

- if you don't use the supporting construction, the fuselage is built by sequentially glueing the rings, which form it.
- if you use the hidden construction, the fuselage is built around it, first assemble the middle section (the one that contains the cockpit).



3. Attach the horizontal and the vertical stabilizers shown on Fig.2. Cut out the dark gray field at the tail of the fuselage and insert the assembly there.

4. Attach the wings to the fuselage.

5. Assemble the base of the engine - elements A15, A16 and A17.

6. If you are building the engine, glue to the base the 14 cylinders elements E2 and glue the ring E1 to A15.

7. Fix the base of the propeller using a metal pin. The assembly is shown on Fig.3. It is glued on the nose of the fuselage at the marked spot on element A1.

8. Put the cover you assembled with elements A9, A19 and A11 on the engine.

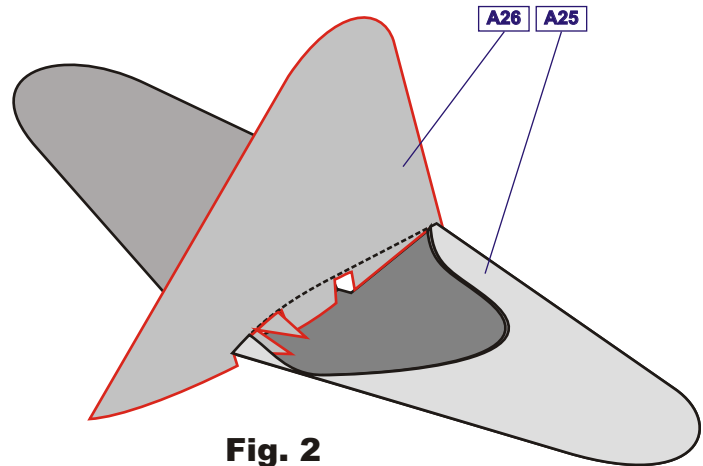

Fig. 2

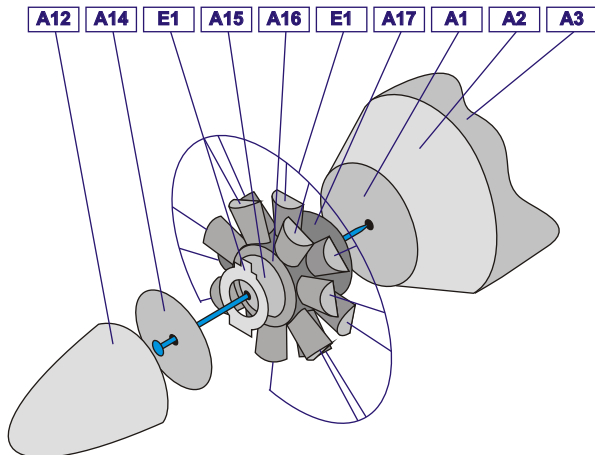

Fig. 3

9. Glue the cockpit.

10. Assemble the main float by glueing the bottom elements first (A29 and A30) to the cross-section (element A28) and then cover with A31. Attach it to the fuselage.

11. Assemble and attach the side floats to the wings.

12. Assemble and glue at the marked spots the propeller blades, the antenna and the Pitot tube.

Refer to Fig.4 for help.

The way to assemble the transporter is shown on Fig.5

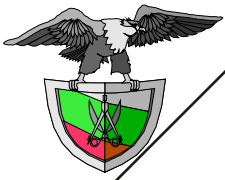

Fig. 4

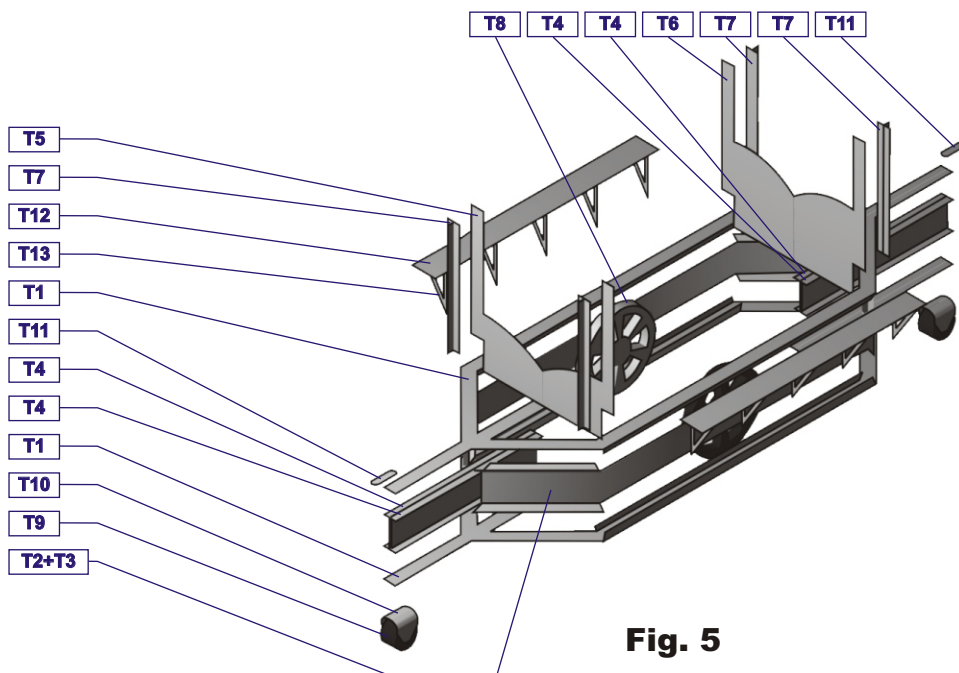
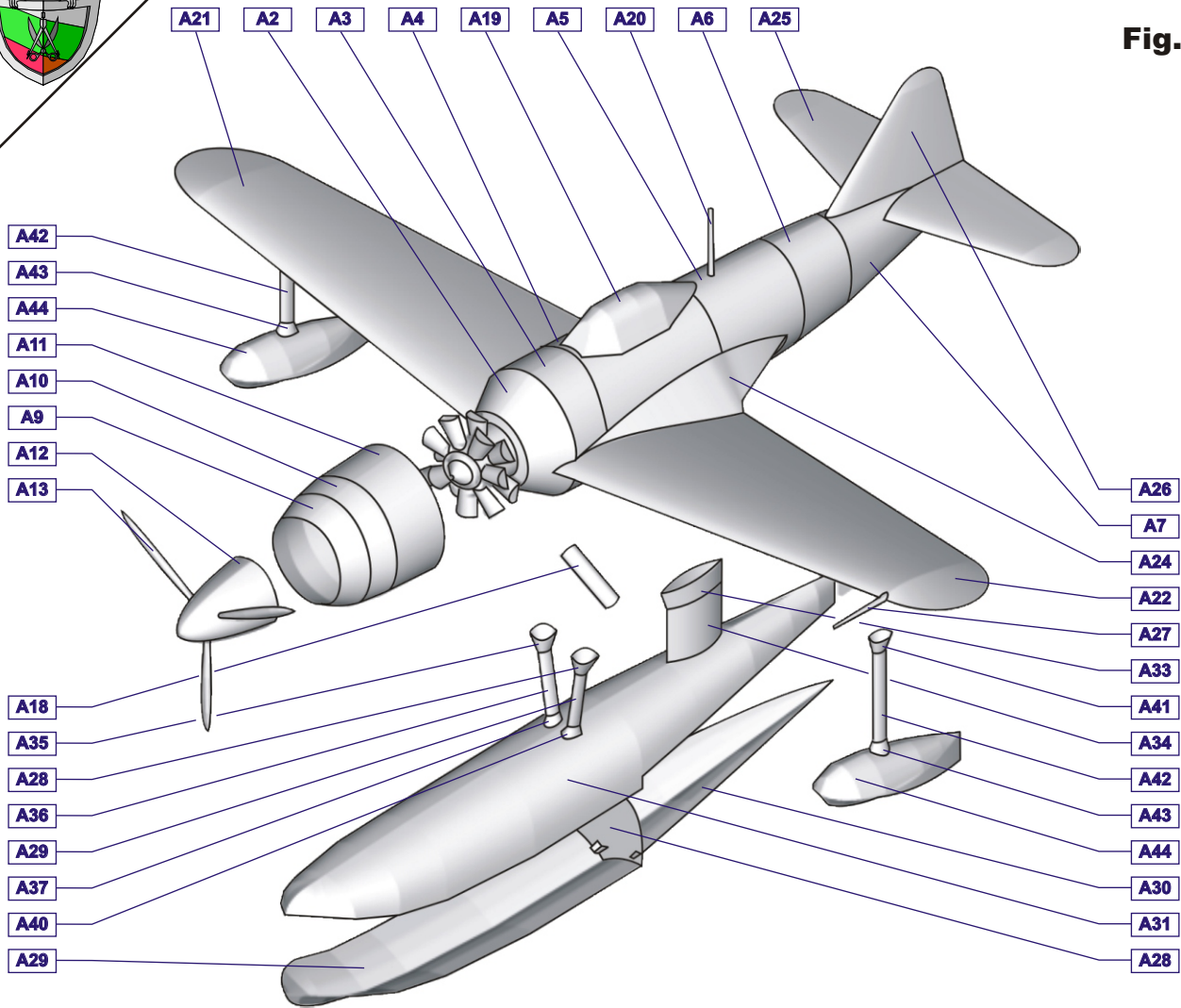
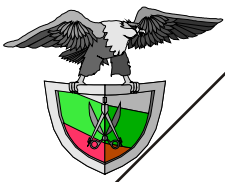

Fig. 5



Element ID	Location (Page#)	Quantity
A1	1	1
A2	1	1
A3	1	1
A4	1	1
A5	1	1
A6	1	1
A7	1	1
A8	1	1
A9	1	1
A10	1	1
A11	1	1
A12	1	1
A13	1	3
A14	1	1
A15	1	1
A16	1	1
A17	1	1
A18	1	2
A19	1	1
A20	1	1
A21	2	1
A22	2	1
A23	2	1
A24	2	1
A25	2	1
A26	2	1
A27	2	1
A28	3	1
A29	3	1
A30	3	1

Element ID	Location (Page#)	Quantity
A31	3	1
A32	3	1
A33	3	1
A34	3	1
A35	3	1
A36	3	1
A37	3	1
A38	3	1
A39	3	1
A40	3	1
A41	3	1
A42	3	1
A43	3	1
A44	3	1
A45	3	1
A46	3	1
A47	3	1
A48	3	1
E1	5	1
E2	5	14
C1	5	1
C2	5	1
C3	5	1
C4	5	1
C5	5	1
C6	5	1
C7	5	1
C8	5	1
C9	5	1
C10	5	1

Element ID	Location (Page#)	Quantity
C11	5	1
C12	5	1
C13	5	1
C14	5	1
C15	5	1
C16	5	2
C17	5	2
C18	5	2
C19	5	2
C20	5	1
C21	5	1
T1	6	2
T2	6	2
T3	6	2
T4	6	4
T5	6	1
T6	6	1
T7	6	4
T8	6	4
T9	6	4
T10	6	2
T11	6	2
T12	6	2
T13	6	10
T14	6	1

Have fun with this model!!!



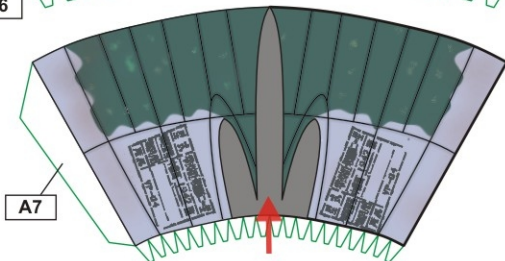
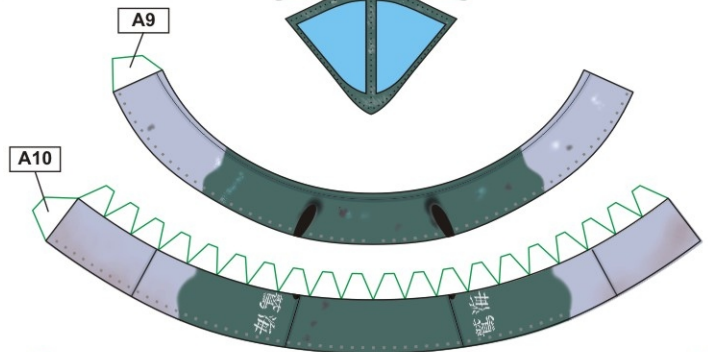
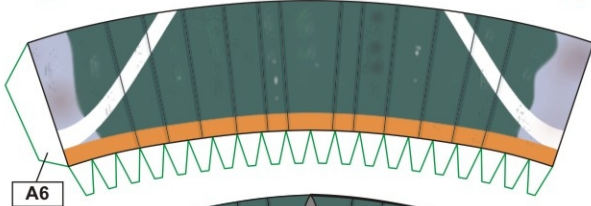
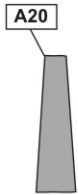
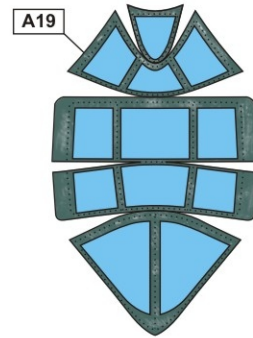
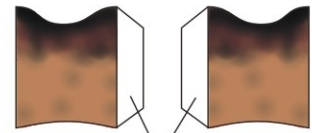
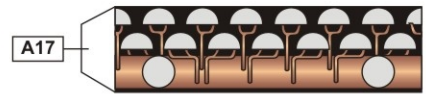
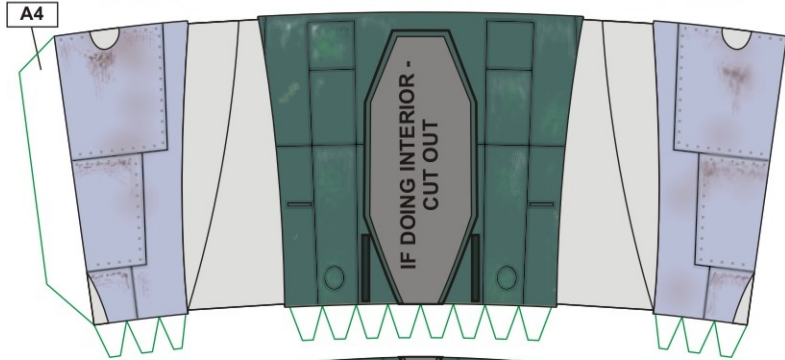
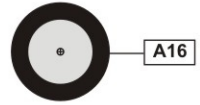
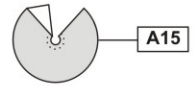
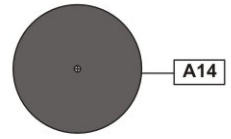
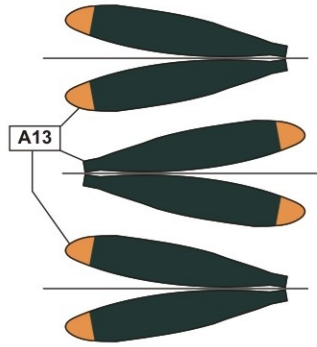
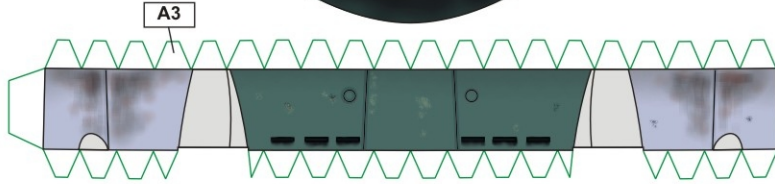
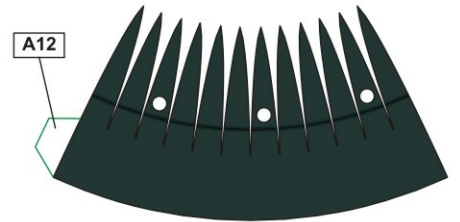
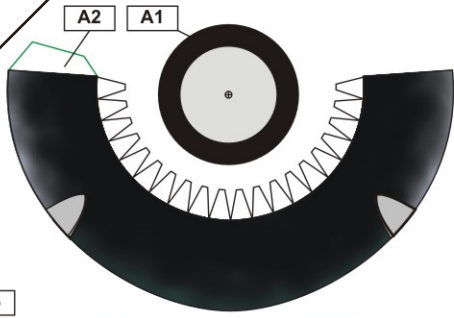
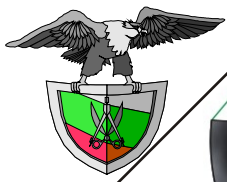

CUT OUT THESE DARK GRAY AREAS AFTER ASSY

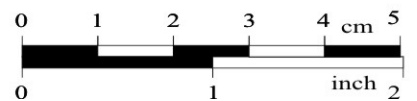
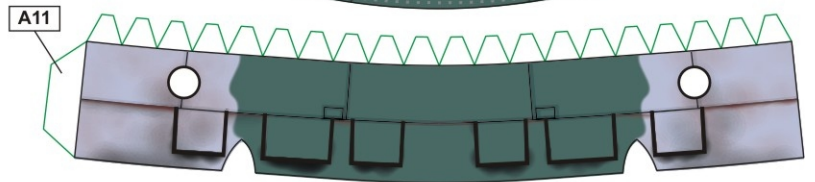
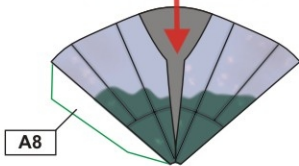

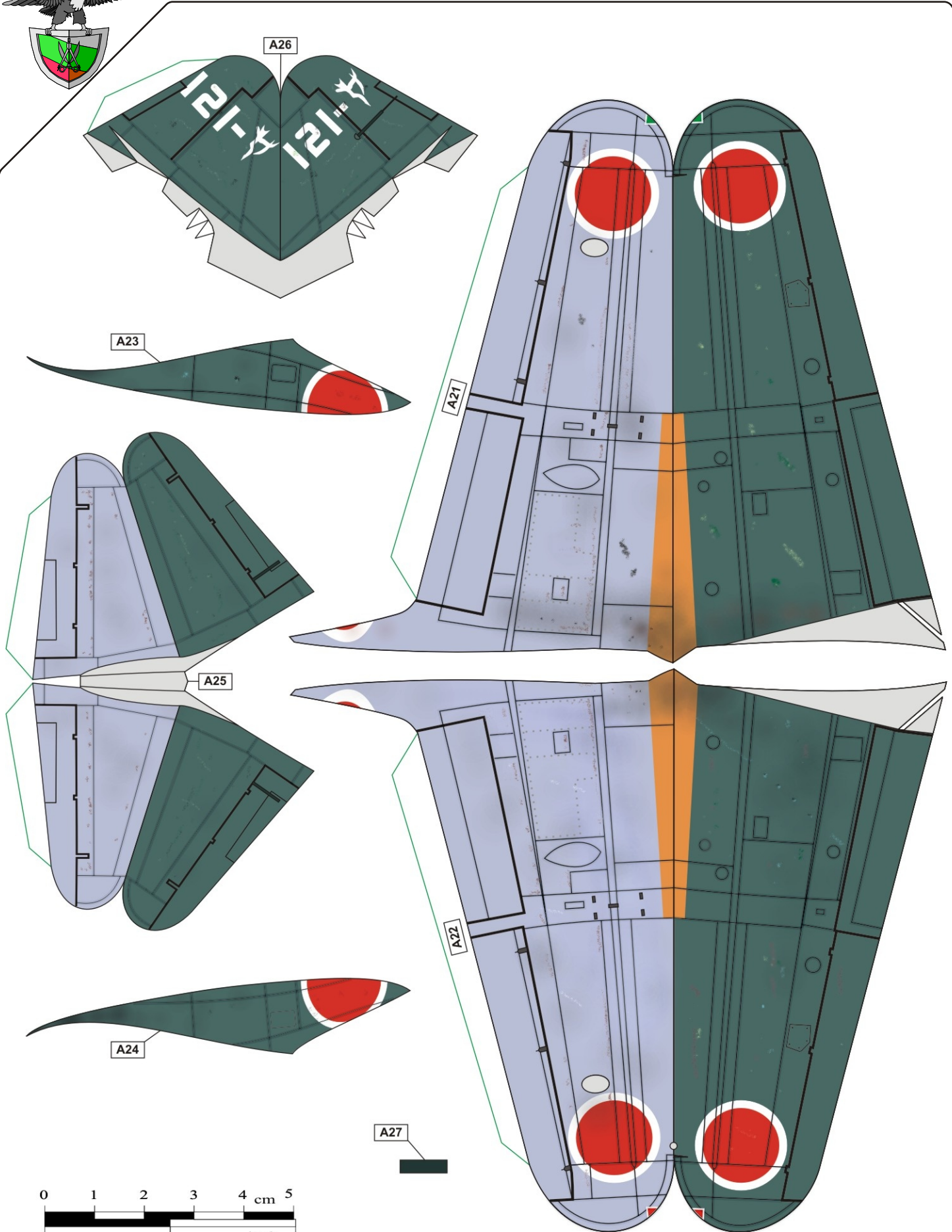
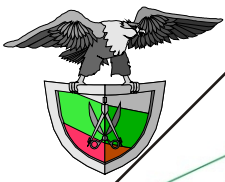

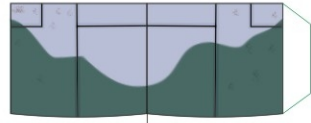
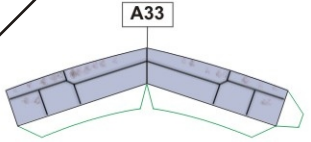
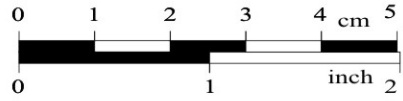
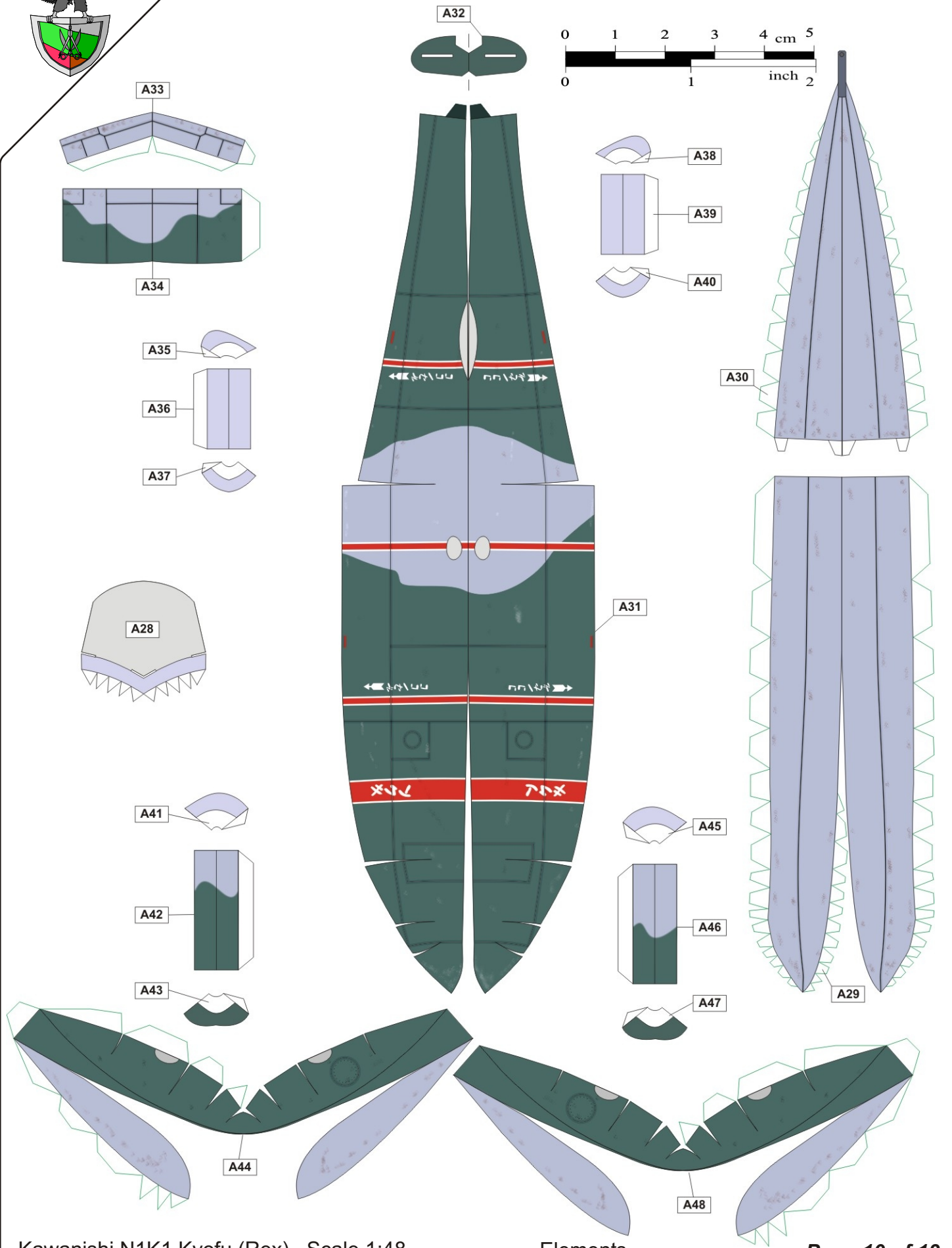
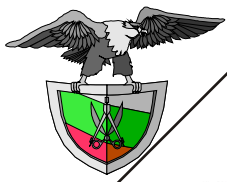

A34

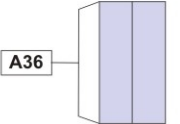
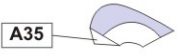

A37



A28

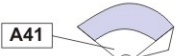

A41

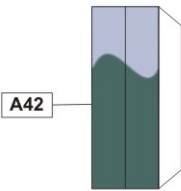

A42



A43

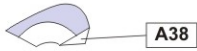

A38

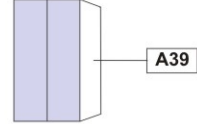

A39

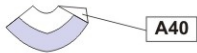

A40

A30

A31



A45

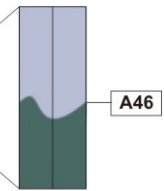

A46



A47

A29

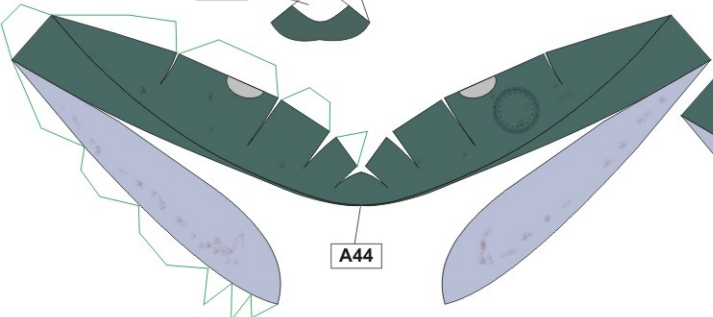

A44

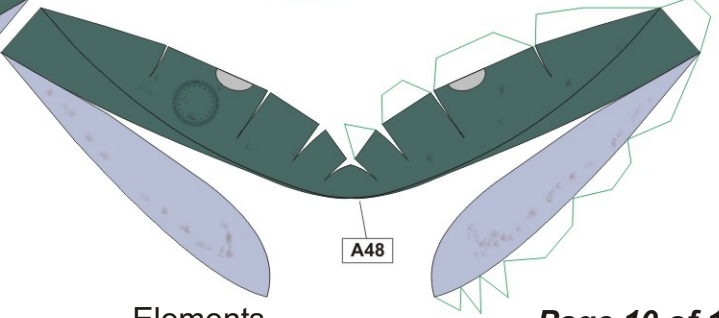

A48

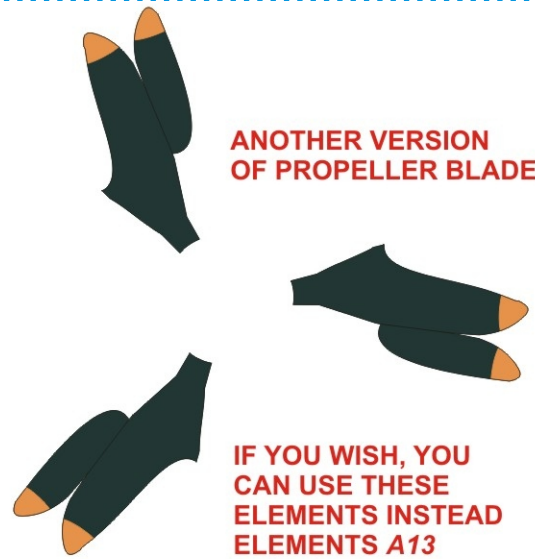
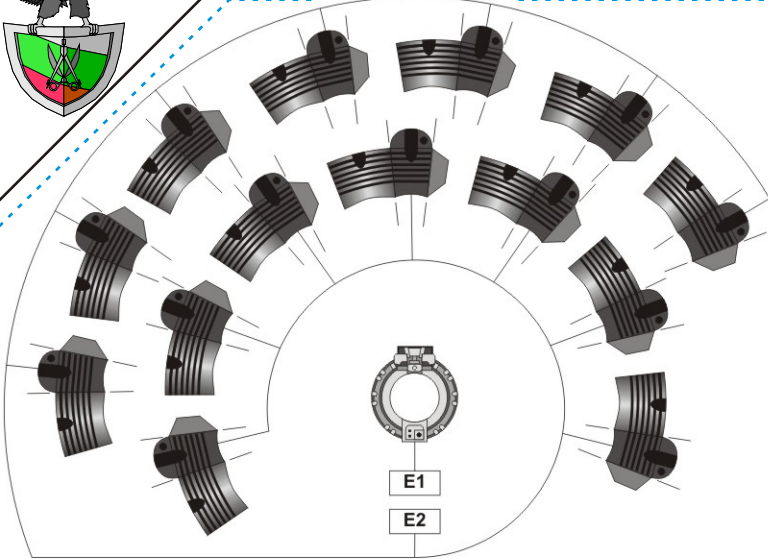
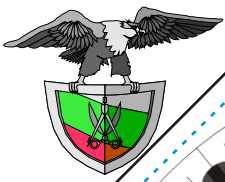

ANOTHER VERSION OF PROPELLER BLADES

IF YOU WISH, YOU CAN USE THESE ELEMENTS INSTEAD ELEMENTS A13

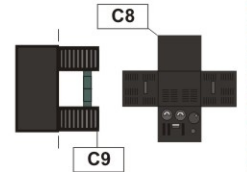
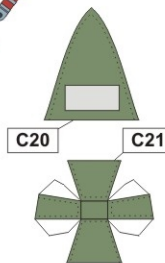
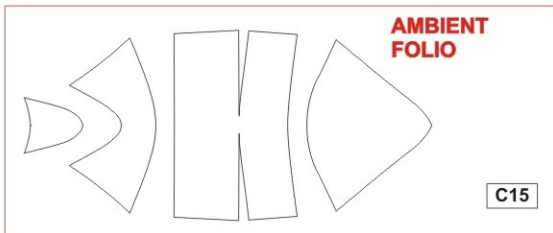
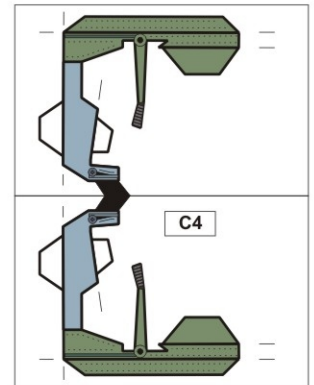
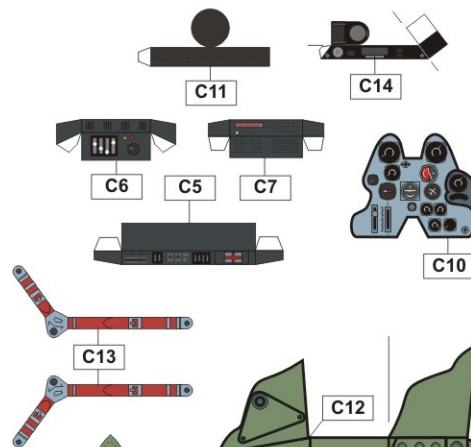
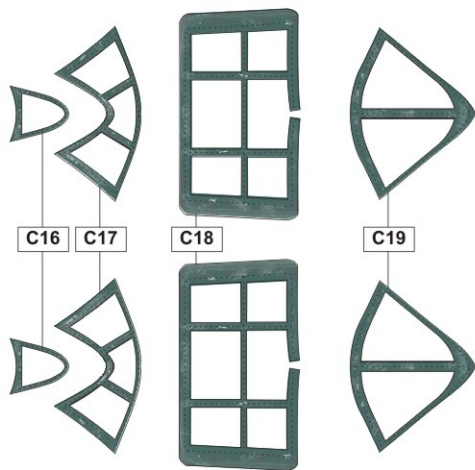

After printing, glue this page to a sheet of thick cardboard

